

Adjustment of the Inclination of Rotary Heat Exchangers GOLD, sizes 70-80,

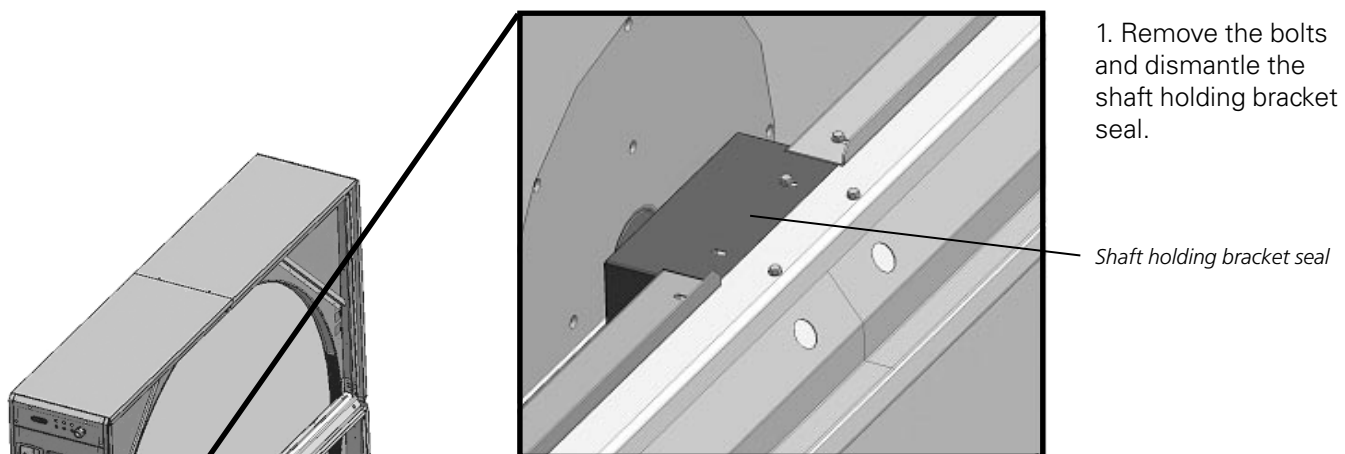

1. Remove the bolts and dismantle the shaft holding bracket seal.

Shaft holding bracket seal

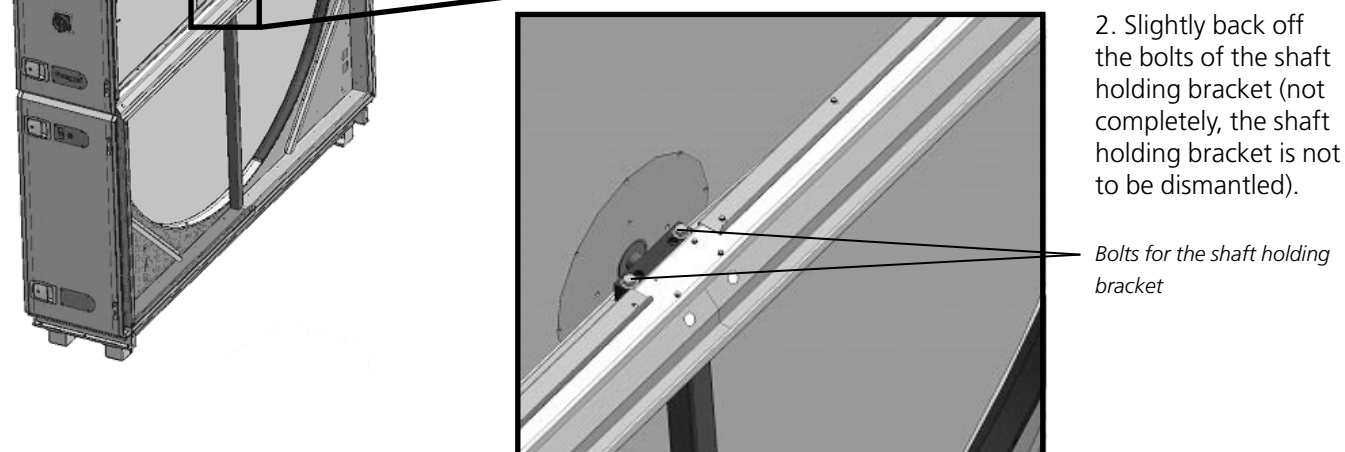

2. Slightly back off the bolts of the shaft holding bracket (not completely, the shaft holding bracket is not to be dismantled).

Bolts for the shaft holding bracket

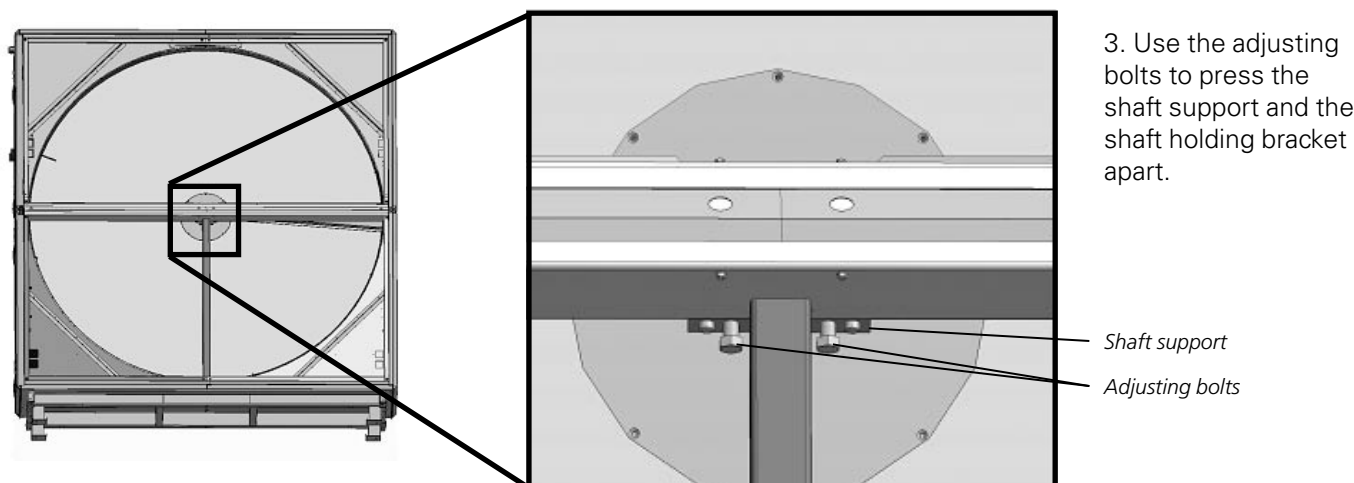

3. Use the adjusting bolts to press the shaft support and the shaft holding bracket apart.

Shaft support

Adjusting bolts

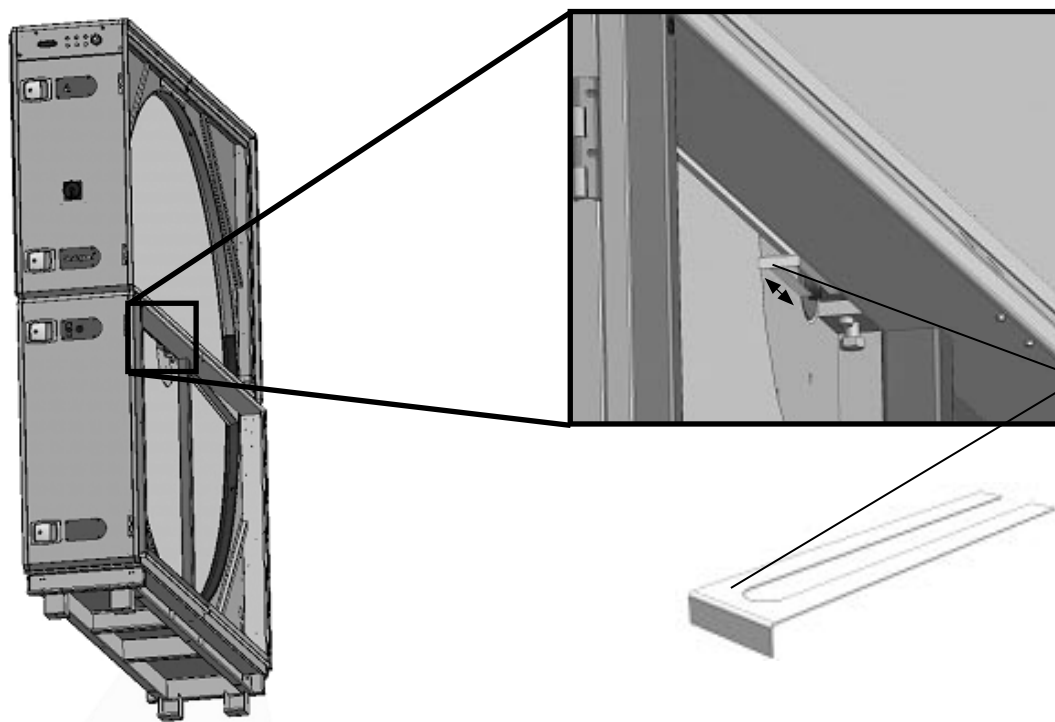

4. Insert or remove shim plates for inclining the rotary heat exchanger to the required inclination (extra shim plates are supplied with the unit).

Shim plate

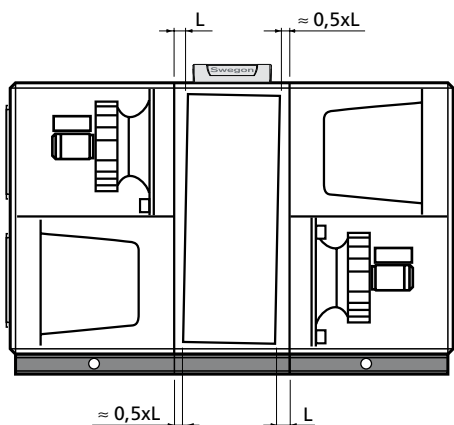

The illustration shows the factory-preset rotor inclination for Fan Arrangement 1. The inclination must always be toward the filter, which means that the inclination for Fan Arrangement 2 is in the other direction.

The rotors inclination may need to be greater in applications that involve high airflows with associated high pressure.

5. **N.B.!**

When reassembling, back out the adjusting bolts and press the shaft holding bracket toward the rotary heat exchanger before you alternately tighten the bolts of the bolted joint. This is done in order to minimise the play between spacing collar and rotor.