



FUNCTION

ARE is a circular measurable controller with motor controlled flow regulation. It has been developed especially for the e.r.i.c. system with constant pressure in branch ducts and requirement controlled air flow. The unit is available in two different designs, partly as an active controller including sound attenuator to be combined with the Swegon low velocity air terminal type VARIZON[®], partly as an active controller to one or more passive supply air diffusers or exhaust air terminals.

QUICK FACTS

- Active damper control
- Manages large air flow ranges
- Cleanable
- For low velocity air terminals, mixing units and exhaust air terminals
- Damper in class 4 air tightness

QUICK GUIDE

AREb Size	FLOW RANGE	
	Min	Flow range l/s At 4 m/s
125	22	50
160	35	85
200	50	140
250	80	200
315	135	320
400	210	500

A flow tolerance of $\pm 10\%$ applies for the minimum flow.

DESIGN

Active circular measurable controller. Designed to be fitted in the duct before the air terminal. Available in two designs.

ARE 1 has been especially developed for the Swegons low velocity air terminal type VARIZON®. In addition to the damper section ARE 1 consists of two further two parts: sound attenuator section and a mounting sleeve with adjustable quick-action catches that hold the damper section and the sound attenuator section together.

ARE 2, which is adapted to control the air flow to one or more passive air terminals, only consists of a damper section with measurement unit.

The damper section consists of a circular sleeve where the ends are fitted with connection nipples sealed by rubber rings. Mounted on the outside of ARE 2 is a damper motor bracket and damper motor. The damper motor shelf is approx. 70-80 mm high to accommodate any duct insulation. The measurement hoses are routed out through the sleeve up to measurement nipples on the damper control bracket.

On ARE 1 the damper motor is directly mounted on the circular sleeve. This is so that it has space behind any duct casing. However it has a small bracket for the measurement nipples. There is a rubber sealed full damper leaf and a measurement unit mounted inside the sleeve.

Max. ambient temperature 60°C.

CONTROL ACCESSORIES

ROOM REGULATOR: KCD or KCW

TEMPERATURE SENSOR: KST

CO₂: KSC

OCCUPANCY SENSOR: KSO

MATERIALS AND SURFACE TREATMENT

The damper is made of galvanized sheet steel. The sound attenuator section and mounting sleeve on ARE 1 are made of galvanized sheet steel with elements of mineral wool and rubber.

PLANNING

A comprehensive planning guide that describes the overall e.r.i.c. concept is given in the technical section.

As the pressure in the branch duct is constant, air terminal selection should be made according to the following:

Select a pressure. Follow the pressure line on the diagram from left to right. The flow range can now be read, with the help of the pressure range lines both the maximum and minimum flows. These flows should be stated in the specification for the air terminal and room regulator KCD or KCW. (See separate product sheet.) Note by selecting constant pressure the sound level in the ceiling drops as the air flow is reduced. In principle ARE is suitable for all air terminals presented in our product catalogue. Please refer to the current product catalogue for information about these.

ARE 2 has been developed for placement in an e.r.i.c. system and normally does not need a sound attenuator between the damper and air terminal as we use a low static pressure.

ARE 1 has been especially developed for the Swegon low velocity air terminal type VARIZON®. A sound attenuator is always included in this concept. Partly to prevent the damper from being placed too close to the inlet of the low velocity air terminal, for which this is not adapted, and partly because there is an air distributor integrated in the sound attenuator

section that ensures the low velocity air terminal's k-factor value.

ARE 1 and 2 are both equipped with a measurement unit for differential pressure measurement. There are demands on a straight section before the damper, in order for the stated measurement method error to be obtained. See table 1 and figure 1.

On ARE 1 measurement of the air flow should normally be made on the air terminal's measurement unit. The air terminal's k-factor can then be used. The damper's measurement unit can be utilised when this is placed further back in the duct system, for example, in another room away from the air terminal.

Table 1

m² = method error B22. The Swedish Council for Building Research's publication, "Methods for measuring the air flow rate in ventilation systems".

Type of disturbance before AREb	Straight section before ARE For $m_2 = 5\%$	Straight section before ARE For $m_2 = 10\%$
One 90° -elbow	3 · ød	2 · ød
Two 90° -elbows on the same level	4 · ød	2 · ød
Two 90° -elbows level perpendicular to each other	4 · ød	2 · ød
On damper 45°	6 · ød	3 · ød
One T-piece	4 · ød	3 · ød

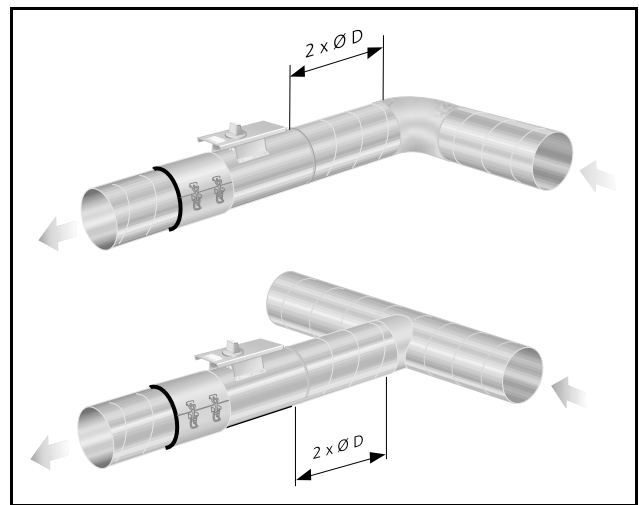

Figure 1. ARE 2, mounting sleeve FSR is ordered separately.

INSTALLATION (See figure 2 and 3)

ARE 1: When the low velocity air terminal is mounted the controller is pushed down into the air terminal's connection. The controller's damper is turned so that the actuator points diagonally or straight backwards against the wall, to make space behind for any duct casing.

ARE 2: Slides into the connecting duct and is secured using a pop rivet or with mounting sleeve FSR.

COMMISSIONING

The air flow rates are normally preset via the room regulator KCD or KCW. Control measurement can either be performed with the traditional k-factor measurement or on the usual test socket.

On ARE 1, control measurement is performed on the air terminal's test socket. This is positioned behind the removable side strip on the side of the air terminal.

On ARE 2, control measurement is performed on the damper unit's measurement nipples.

The K-factor is stated on the product label. The K-factors are also stated in the current commissioning instructions. This is available from our website.

MAINTENANCE

Clean if necessary with the help of a vacuum cleaner or by wiping with a cloth.

DECLARATION

The product is CE marked.

CE declaration and Environmental Product Declaration are available from our website.

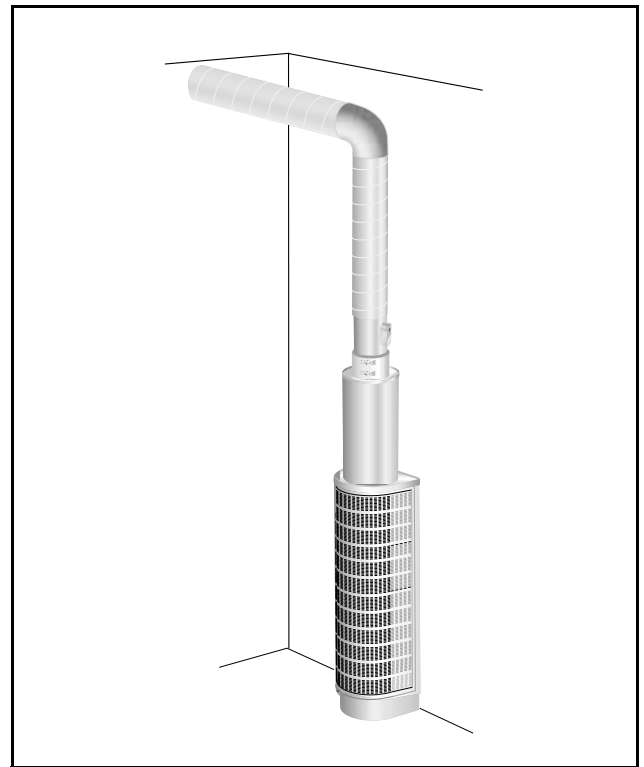

Figure 2. ARE 1 for low velocity air terminal.

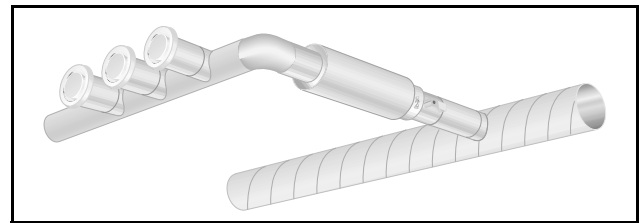

Figure 3. ARE 2 for duct installation.



Electrical data

Input voltage	24V AC ±20% 50-60 Hz
Power consumption	5 VA
Ambient temperature:	
Operation	-20°C - +55°C
Storage	-20°C - +55°C
Enclosure:	
Enclosure class	IP 54
Standard damper motor:	
ASM 114 SF 901	5 VA

Connection

ARE receives its power supply via the room regulator KCD or KCW. See the wiring diagram. (Also see the technical section.)

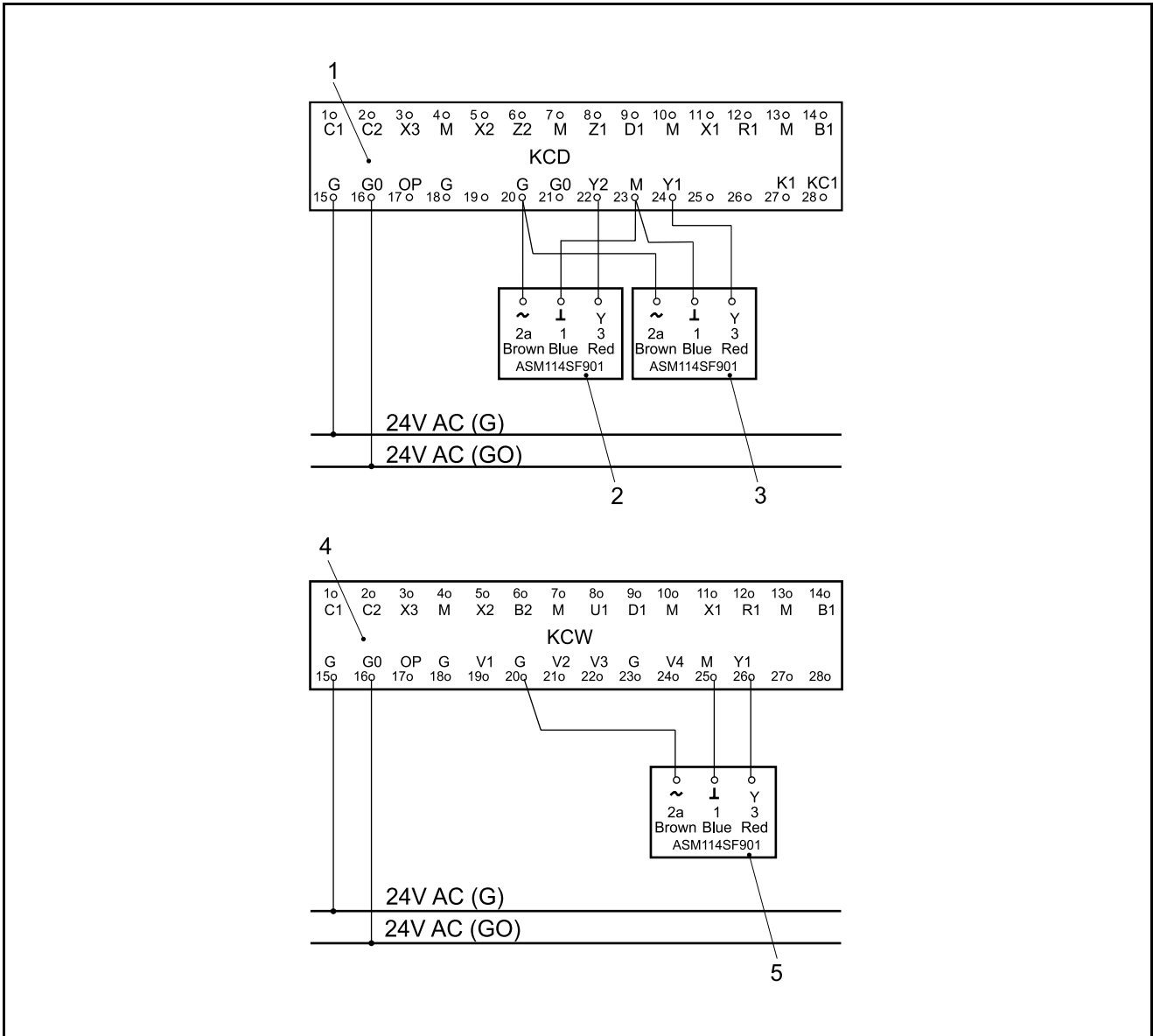

Figure 4. Wiring diagram.

1. Room regulator kCD
2. ARE for supply air
3. ARE for exhaust air
4. Room regulator KCW
5. ARE for supply or exhaust air

TECHNICAL DATA

Sound level

- Sound level dB(A) for room 10 m² equivalent sound absorption area.
- Applies to a complete installation with low velocity air terminals VARIZON[®] sound attenuator and damper.

Table 1

Correction factor, K_{OK} for ARE 1, including sound attenuator.

Size AREb 1	Mid-frequency (Octave band) Hz							
	63	125	250	500	1000	2000	4000	8000
125	6	5	4	-1	-2	-6	-9	-13
160	7	5	4	0	-2	-5	-10	-14
200	6	4	3	0	-2	-4	-11	-12
250	4	4	4	0	-1	-4	-12	-9
315	3	5	4	-1	-1	-5	-11	-11
400	3	5	5	1	-1	-5	-12	-10
Tol. ±	2	2	2	2	2	2	2	2

Table 2

Attenuation data for ARE 1 with sound attenuator and VARIZON[®], including opening attenuation.

Size AREb 1	Mid-frequency (Octave band) Hz							
	63	125	250	500	1000	2000	4000	8000
125	25	18	17	20	33	31	27	22
160	22	15	14	18	31	28	24	20
200	20	13	9	14	29	28	23	21
250	17	11	7	11	26	23	18	18
315	15	10	6	14	24	21	19	21
400	14	9	5	12	25	20	18	21
Tol. ±	2	2	2	2	2	2	2	2

Engineering graphs - ARE 1

Air flow - Pressure drop - Sound level

- The graph should not be used for commissioning.
- The diagrams show pressure and flow lines at different damper positions in %.
- dB(A) applies for a normally attenuated room (4 dB room attenuation).

AREb 1-125 + DHCe / DVCe

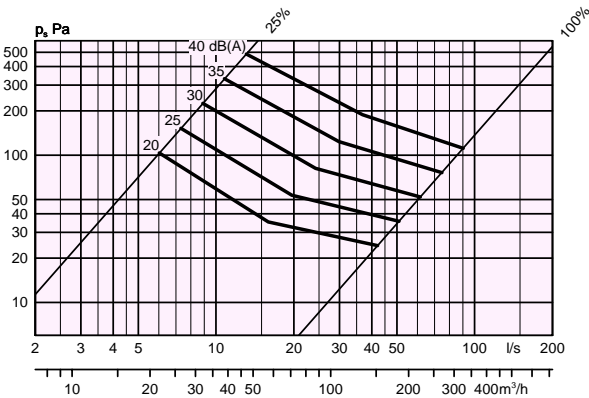

AREb 1-160 + DHCe / DVCe

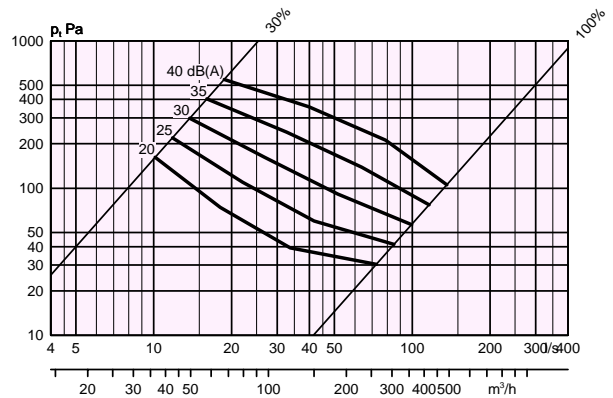

Engineering graphs - ARE 1

Air flow - Pressure drop - Sound level

- The graph should not be used for commissioning.
- The diagrams show pressure and flow lines at different damper positions in %.
- dB(A) applies for a normally attenuated room (4 dB room attenuation).

AREb 1-200 + DHCe / DVCe

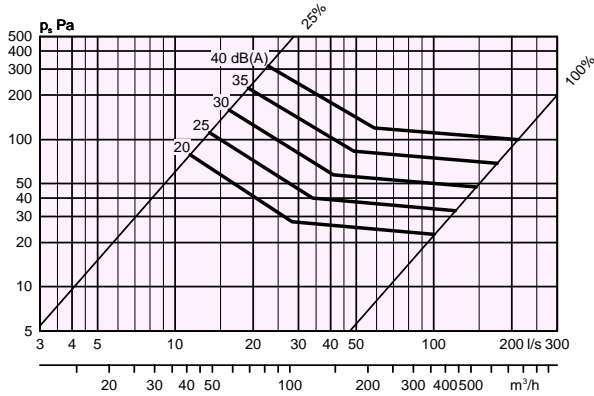

AREb 1-250 + DHCe / DVCe

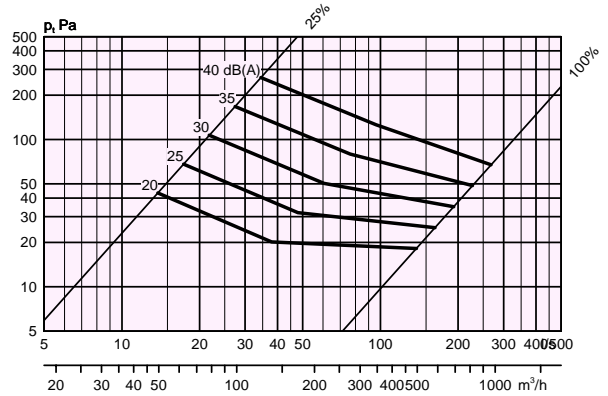

AREb 1-315 + DHCe / DVCe

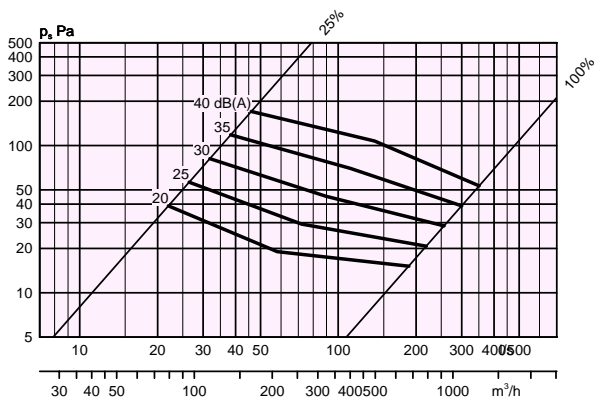

AREb 1-400 + DHCe / DVCe

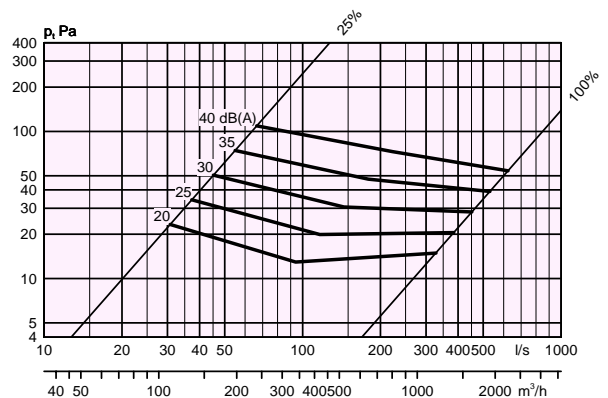

TECHNICAL DATA

Sound power level

The diagram for the different sizes shows the total generated sound power ($L_{w\text{tot}}$ dB) to the duct, as a function of the air flow and pressure drop across the damper. By correcting $L_{w\text{tot}}$ with the correction factors from Table 2 the sound power levels are obtained for respective octave bands ($L_{w\text{tot}} + K_{OK}$).

Table 1

Correction factor, K_{OK} for ARE 2

Size	Mid-frequency (Octave band) Hz							
	63	125	250	500	1000	2000	4000	8000
125	1	-2	-8	-13	-16	-27	-33	-37
160	2	-3	-8	-13	-16	-24	-32	-39
200	3	-2	-8	-13	-16	-23	-30	-36
250	3	-4	-7	-11	-15	-21	-28	-33
315	2	-3	-7	-12	-17	-24	-30	-34
400	3	-2	-9	-11	-16	-22	-28	-35
Tol. ±	2	2	2	2	2	2	2	2

Engineering graphs - ARE 2

Air flow - Pressure drop - Sound level

- The graph should not be used for commissioning.
- The diagrams show pressure and flow lines at different damper positions in %.
- $L_{w\text{tot}}$ dB applies to sound in the duct.

AREb 2-125

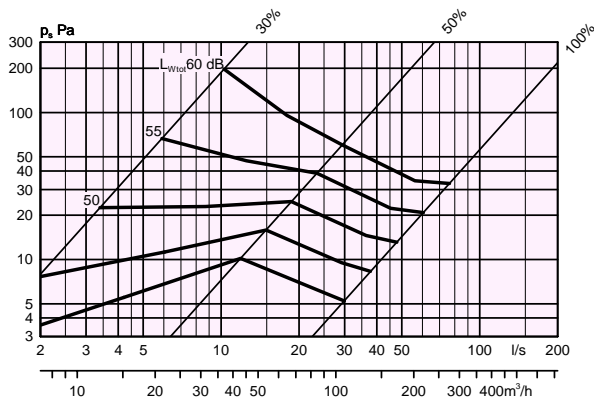

AREb 2-160

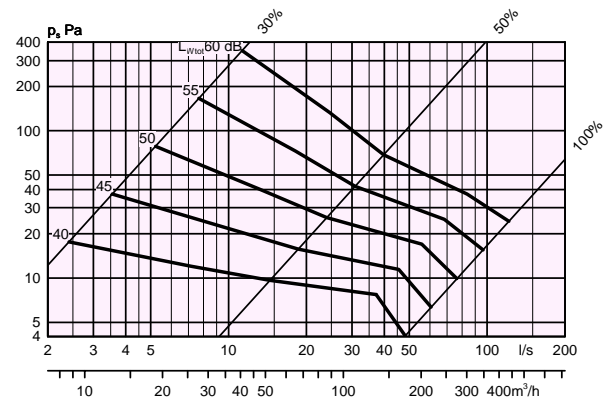

Engineering graphs - ARE 2

Air flow - Pressure drop - Sound level

- The graph should not be used for commissioning.
- The diagrams show pressure and flow lines at different damper positions in %.
- $L_{w\text{tot}}$ dB applies to sound in the duct.

AREb 2-200

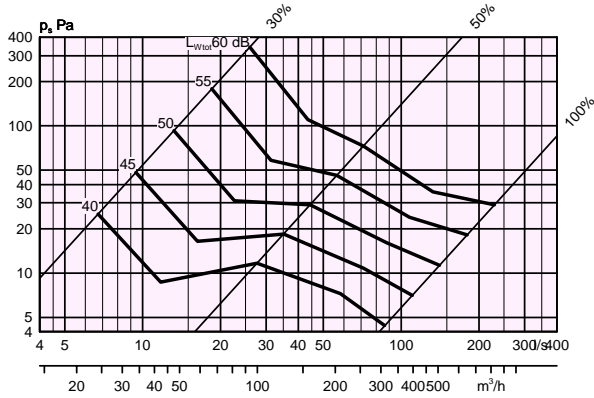

AREb 2-250

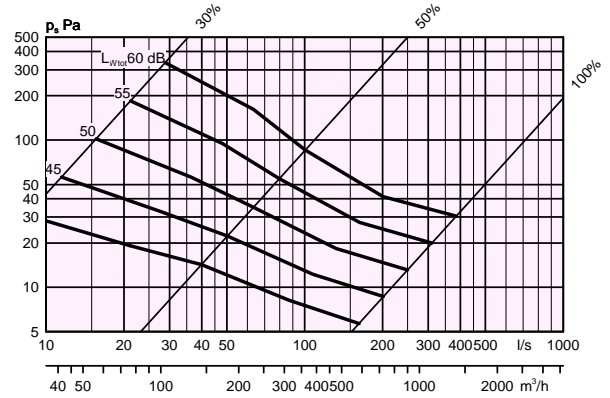

AREb 2-315

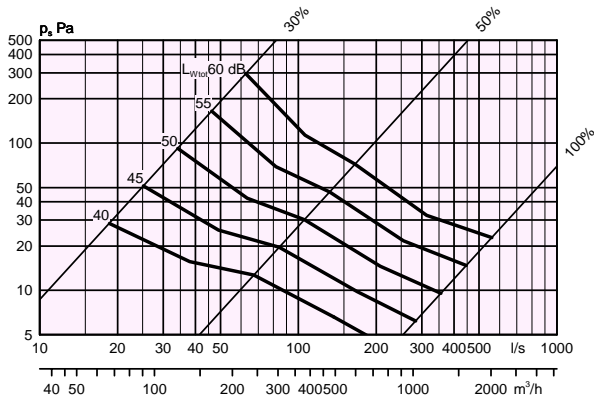

AREb 2-400

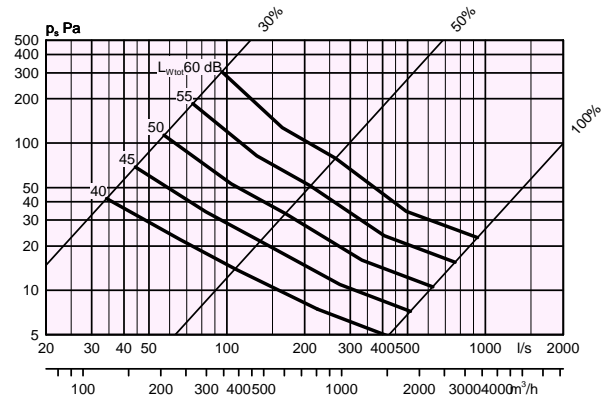

DIMENSIONS AND WEIGHT

AREb 1

Size	ØC	Ød	G	H	Weight,kg
125	225	124	406	600	7,2
160	260	159	406	600	8,7
200	300	199	422	600	11,3
250	350	249	502	600	12,8
315	415	314	584	900	26,8
400	500	399	618	900	30,8

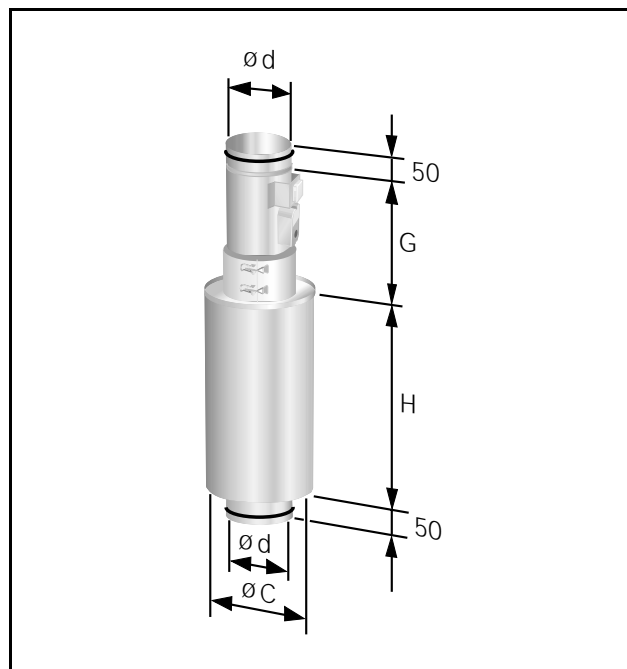

Figure 5. ARE 1 for low velocity air terminals.

AREb 2

Size	A	B	Ød	H	Weight,kg
125	356	256	124	75	1,5
160	356	256	159	75	1,3
200	372	272	199	75	1,6
250	452	352	249	75	2,1
315	534	434	314	75	3,0
400	568	468	399	80	5,0

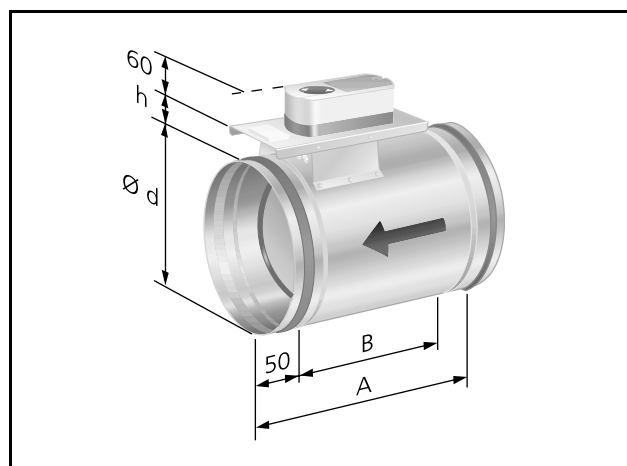

Figure 6. ARE 2 duct installation.



AREb

ORDER KEY

Product designation

Active controller AREb -a -bbb

Variants:

1 = For low velocity air terminals

2 = For duct installation

Size: 125, 160, 200, 250, 315, 400

Accessories

Mounting sleeve FSRc

Control accessories

KCD Room regulator

KCW Room regulator

KST Temperature sensor

KSC CO₂

KSO Occupancy sensor

Specified in respective product sheets

SPECIFICATION EXAMPLE

Swegons active controller type AREb, with following functions:

- Active damper control
- Cleanable, removable
- Damper in class 4 air tightness
- Damper actuator for the e.r.i.c. system
- Mounting sleeve FSR
- Sound attenuator SORDO for low velocity air terminal VARIZON®